

Motorcycle magneto synchronous voltage regulator control IC

Features

- Adopt zero voltage regulating mode
- High power synchronous voltage regulator
- Timely pressure regulation when over voltage
- Hot plug protection
- he power of each phase
- Power supply modulation voltage is adjustable
- Ultra-low static current
- Simple application scheme
- Available packages:LQFP32L

Applications

- high power magneto applications

Description

MST007 is a control IC used for synchronous voltage regulator of motorcycle magneto, suitable for high power magneto applications.

It has built-in multiple protection mechanisms. Protect the load from high voltage shock when the battery is disconnected. The zero voltage regulation method can suppress the electromagnetic interference of the system and reduce the heat load of the voltage regulator. Through internal timing management, the power of each phase is evenly distributed, avoiding the phenomenon of single phase power concentration, controlling the steady and orderly work of the voltage regulator, ensuring the reliable and durable motorcycle charging system. The use of integrated IC can reduce the static current consumption and extend the battery life.

Typical Application

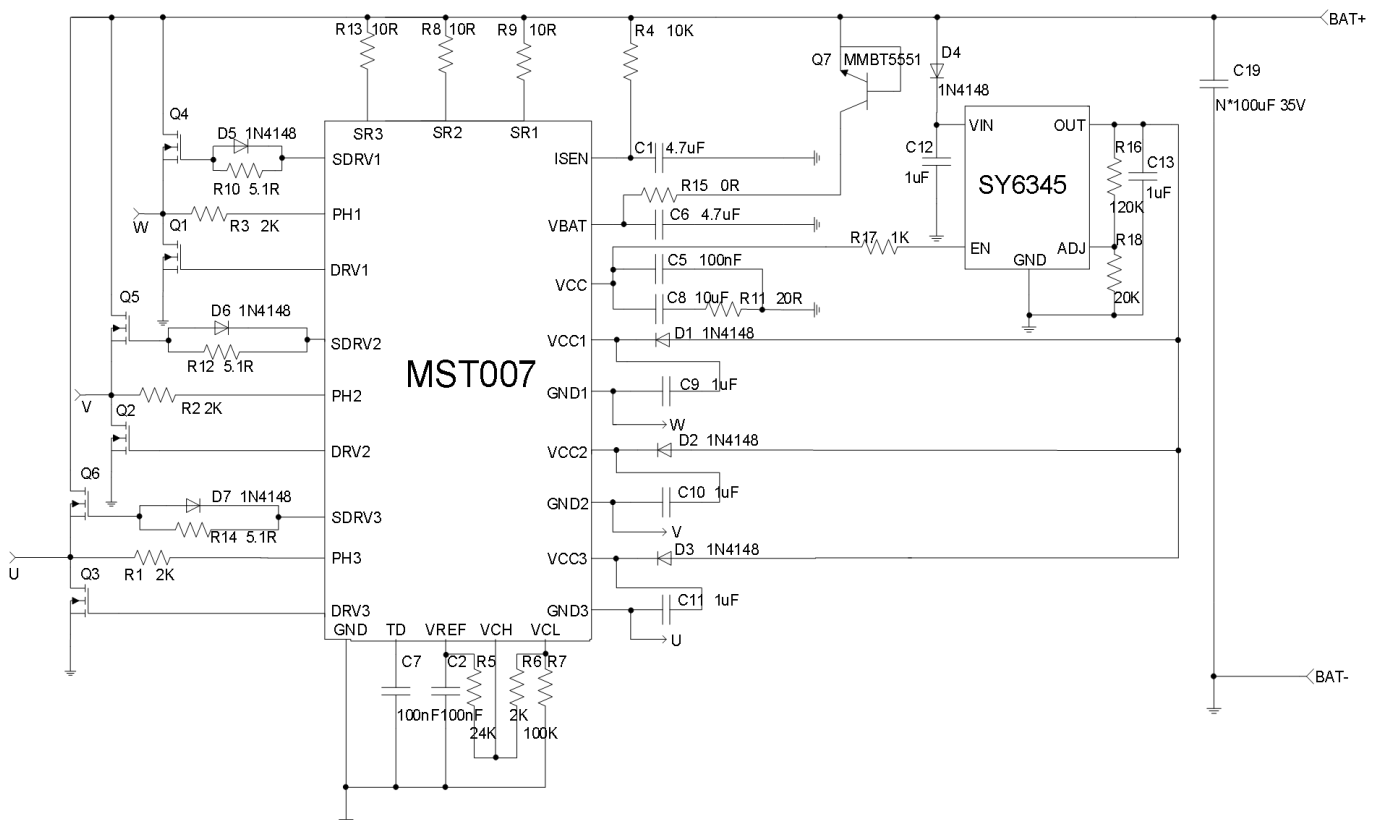

Pin Configuration and Functions

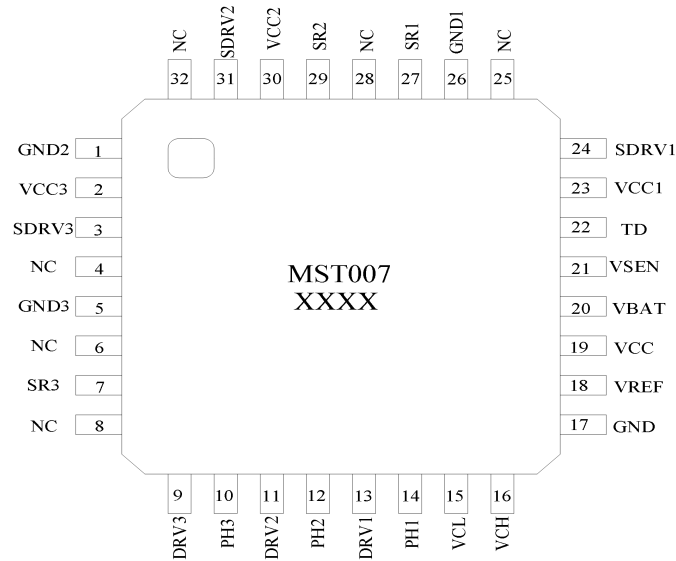

Pin Functions

Pin	Name	Discription
1	GND2	GND port on the second phase tube drive
2	VCC3	VCC port on third phase tube drive circuit
3	SDRV3	The third phase tube drive circuit drives the port
4,6,8,25,28,32	NC	Empty foot
5	GND3	The third phase is the GND port of the tube drive
7	SR3	Third phase high sampling end
9	DRV3	Third phase lower tube drive port
10	PH3	Third phase voltage sampling end
11	DRV2	Second phase lower tube drive port
12	PH2	Second phase voltage sampling end
13	DRV1	First phase lower tube drive port
14	PH1	First phase voltage sampling end
15	VCL	Set the lower limit of adjusting voltage
16	VCH	Set upper adjustment voltage limit
17	GND	System ground
18	VREF	2.5v reference voltage
19	VCC	Internal power output end of chip
20	VBAT	Battery end
21	VSEN	Battery voltage detection terminal
22	TD	Magneto operation detection port
23	VCC1	VCC port of first phase upper tube drive circuit
24	SDRV1	First phase upper tube drive port
26	GND1	The GND port of the first phase tube driver
27	SR1	First phase high sampling end
29	SR2	Second phase high sampling end
30	VCC2	The VCC port of the second phase tube driver circuit
31	SDRV2	Second phase on tube drive port

Absolute Maximum Ratings

Feature	Symbol	Range	Units
VCC3 to GND3		-0.3 to 5.5	V
SDRV3 to GND3		-0.3 to 5.5	V
VCC2 to GND2		-0.3 to 5.5	V
SDRV2 to GND2		-0.3 to 5.5	V
VCC1 to GND1		-0.3 to 5.5	V
SDRV1 to GND1		-0.3 to 5.5	V
SR1 to GND1		-0.3 to 45	V
SR2 to GND2		-0.3 to 45	V
SR3 to GND3		-0.3 to 45	V
PH1 to GND		-0.3 to 40	V
PH2 to GND		-0.3 to 40	V
PH3 to GND		-0.3 to 40	V
DRV1 to GND		-0.3 to 20	V
DRV2 to GND		-0.3 to 20	V
DRV3 to GND		-0.3 to 20	V
VBAT to GND		-0.3 to 40	V
VCC to GND		-0.3 to 20	V
TD to GND		-0.3 to 5.5	V
VCH to GND		-0.3 to 5.5	V
VCL to GND		-0.3 to 5.5	V
VREF to GND		-0.3 to 5.5	V
VSEN to GND		-0.3 to 40	V
Work junction temperature		-40 to 125	°C
Store the junction temperature		-40 to 150	°C
Get to environmental thermal resistance (theta JA)(θ _{JA})	LQFP32L	125	°C/W

Note:

exceeding the range specified by the rated parameters will cause damage to the chip, and the working state of the chip beyond the range of rated parameters cannot be guaranteed. Exposure outside the rated parameter range will affect the reliability of the chip.

Electrical Characteristics

(At $T_A=25^{\circ}\text{C}$, $V_{\text{BAT}}=12\text{V}$ unless otherwise noted)

Characteristics	Symbol	Conditions	Min	Typ	Max	Units	
Voltage regulator output voltage	V_{BAT}	Magneto connected to a battery or under load	14	14.5	15	V	
Operating voltage	$V_{\text{CC_MAX}}$	PH1=PH2=PH3=0 $V_{\text{BAT}}=7\text{V}$ to 15V	4	—	15	V	
VREF voltage	V_{REF}	PH1=PH2=PH3=0 $V_{\text{BAT}}=7\text{V}$ to 15V	A	2.475	—	2.5	V
			B	2.5	—	2.525	
			C	2.465-2.475 and 2.525-2.535			
Quiescent current	I_{Q}	$V_{\text{BAT}} = 12\text{V}$	—	60	—	uA	
Phase voltage from positive to negative zero	$V_{\text{ZERO_P}}$	$V_{\text{BAT}} = 12\text{V}$	3	5	7	mV	
Phase voltage from positive to negative zero	$V_{\text{ZERO_N}}$		-7	-5	-3	mV	
Over voltage protection voltage	V_{OVP}	No load	20	21	22	V	
Lower tube drive current	I	at room temperature (25°C)	—	20	—	mA	

Note:(1) Dropout Voltage is the voltage difference between the input and the output at which the output voltage drops 2% below its nominal value.

Detailed Description

Overview

MST007 is a control IC used for synchronous voltage regulator of motorcycle magneto, suitable for high power magneto applications.

It has built-in multiple protection mechanisms. Protect the load from high voltage shock when the battery is disconnected. The zero voltage regulation method can suppress the electromagnetic interference of the system and reduce the heat load of the voltage regulator. Through internal timing management, the power of each phase is evenly distributed, avoiding the phenomenon of single phase power concentration, controlling the steady and orderly work of the voltage regulator, ensuring the reliable and durable motorcycle charging system. The use of integrated IC can reduce the static current consumption and extend the battery life.

Zero crossing point detection

Zero-crossing detection function is shown in figure 1. When the phase voltage signal rises from negative voltage to 5mV, it is judged that the output current of the corresponding phase of magneto increases from negative to positive crossing zero. The phase control circuit outputs low level, the MOS tube of the lower phase is turned off, the MOS tube of the upper phase is turned on, and the voltage regulator is charged for the battery; Similarly, when the input phase voltage signal drops from positive voltage to -5mv, it is judged that the output current of the corresponding magneto phase goes from positive to negative crossing zero. The control circuit of this phase outputs high level, the MOS tube of this phase is on, the MOS tube of this phase is off, and the voltage regulator stops charging the battery.

Suppose N type MOSFET conduction impedance of about 10mΩ, so in the magneto output current by negative current up to 0.5A, from negative to positive judgment for the phase zero; When the output current of magneto decreases from positive current to -0.5A, it is judged that the phase changes from positive to negative crossing zero.

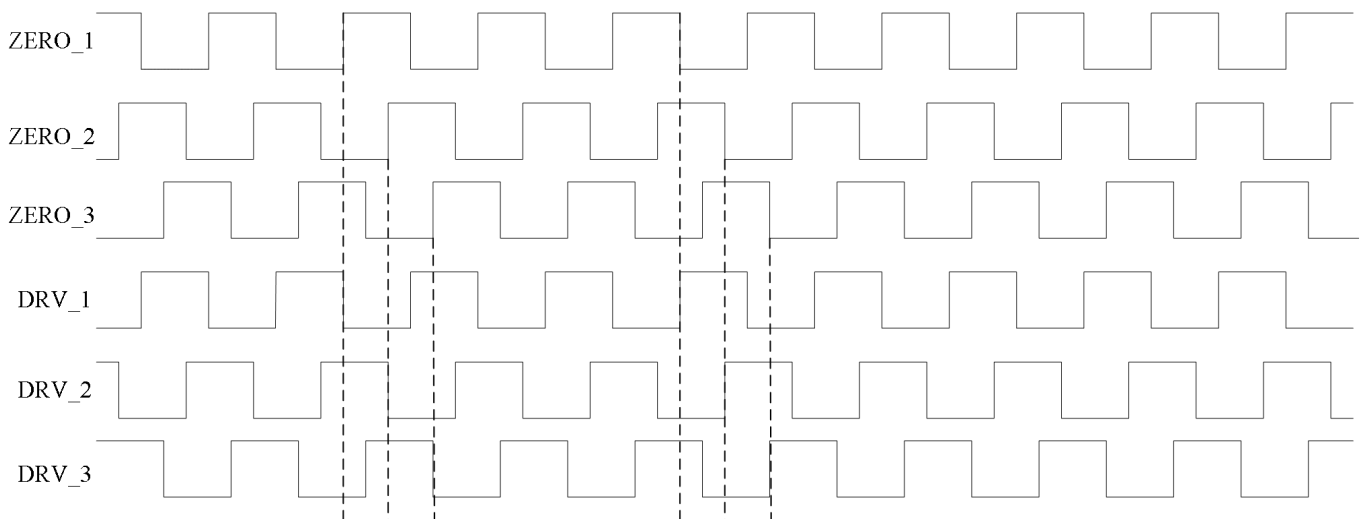

Remarks:

- 1.ZERO_1、ZERO_2、ZERO_3 are the zero-crossing detection signals of each phase voltage.
- 2.DRV_1、DRV_2、DRV_3 are drive output signals of each phase respectively.

Typical Application 1

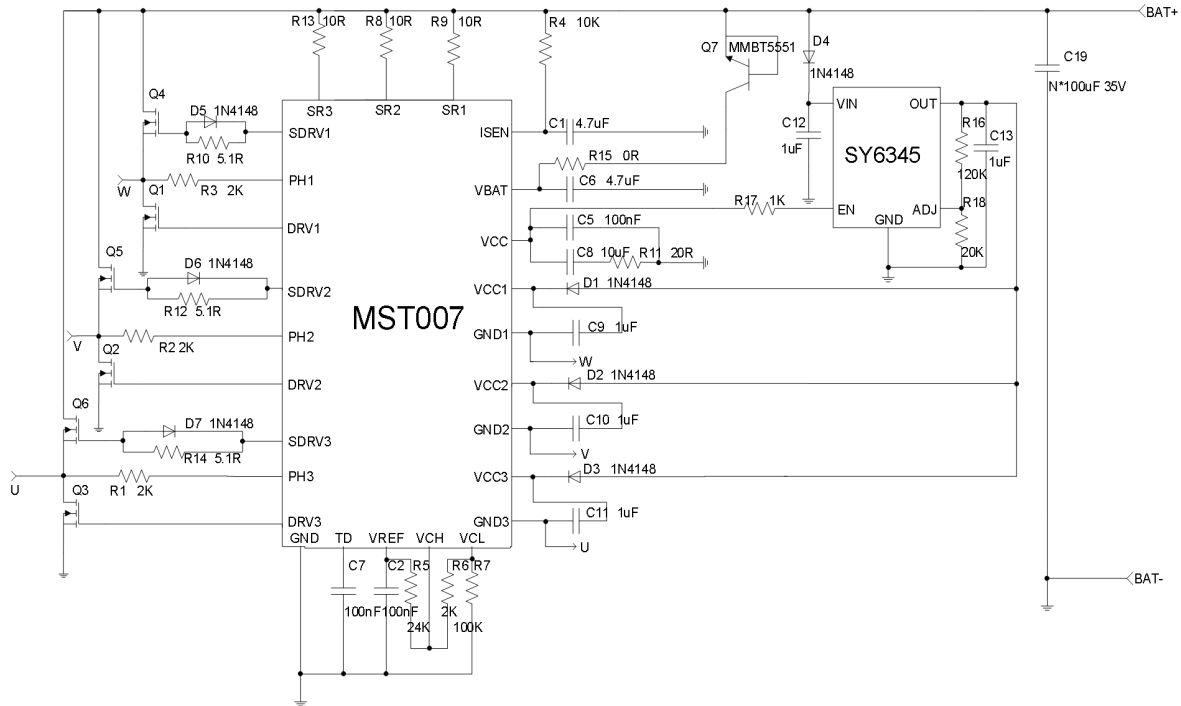

Typical Application 2

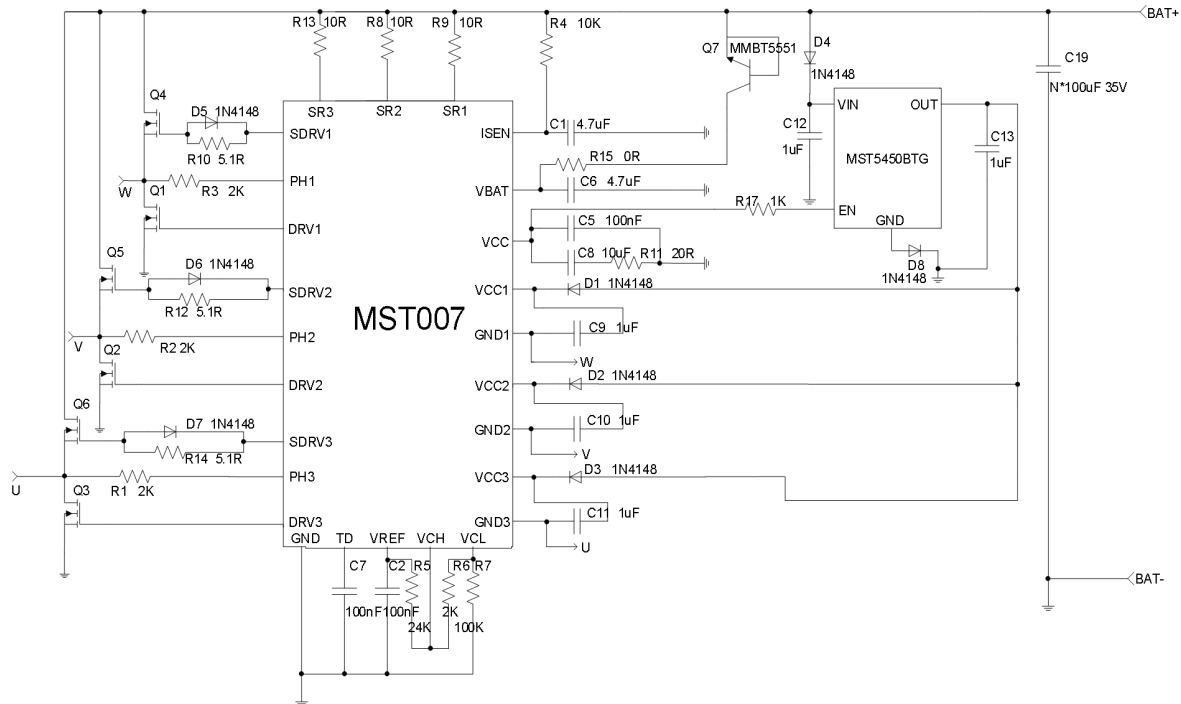

Voltage regulation mode

MST007 can set the modulation voltage by setting the upper and lower voltage of the battery.

The setting formula of upper and lower limits of adjusting voltage is :

$$V_{ADJ_L} = \frac{R_7}{R_5 + R_6 + R_7} \times 2.5V \times 7.25V$$

$$V_{ADJ_H} = \frac{R_6 + R_7}{R_5 + R_6 + R_7} \times 2.5 \times 7.25V$$

The setting formula of adjusting voltage center value is :

$$V_{ADJ} = \frac{R_6 + 2R_7}{2(R_5 + R_6 + R_7)} \times 2.5 \times 7.25V$$

The setting formula of adjusting voltage peak-to-peak value difference is :

$$V_{ADJ} = \frac{R_6}{R_5 + R_6 + R_7} \times 2.5 \times 7.25V$$

The working principle of voltage regulating mode is shown in figure 2. By sampling the battery voltage, when the sampling voltage is lower than the preset lower limit voltage value, the voltage regulator system turns off the corresponding lower MOS tube and opens the corresponding upper MOS tube in the positive half cycle of each phase to charge the battery or load .

Similarly, when the sampling voltage is higher than the preset upper limit voltage value, the voltage regulator system conducts the lower MOS tube of the corresponding phase in the positive half cycle of each phase, and closes the upper MOS tube of the corresponding phase to stop charging the battery or load.

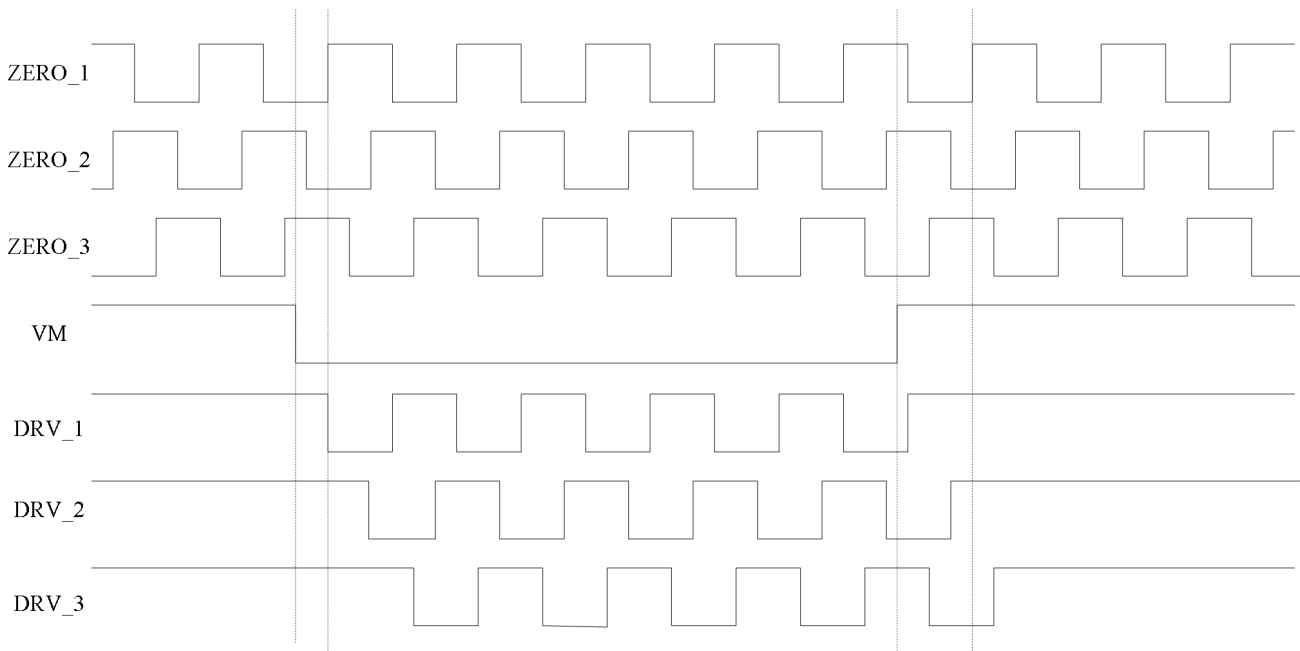

Remarks:

- 1.ZERO_1、ZERO_2、ZERO_3 are the zero-crossing detection signals of each phase voltage.
- 2.VM is for adjusting voltage detection signal.
- 3.DRV_1、DRV_2、DRV_3 are drive output signals of each phase respectively.

At the same time, MST007 has built-in automatic equalization logic to ensure the equal period of output of each phase in the voltage regulation process, and to avoid the heating problem of individual components caused by too large average current of a single phase.

Over voltage mode

The working principle of over voltage mode is shown in figure 3. By sampling the phase voltage, when the phase voltage is higher than the over voltage protection voltage 21V, the lower MOS tube of the corresponding phase is immediately switched on, and the upper MOS tube of the corresponding phase is immediately turned off. The voltage of the phase is pulled down, and the normal output can be resumed until the positive zero crossing of the next cycle.

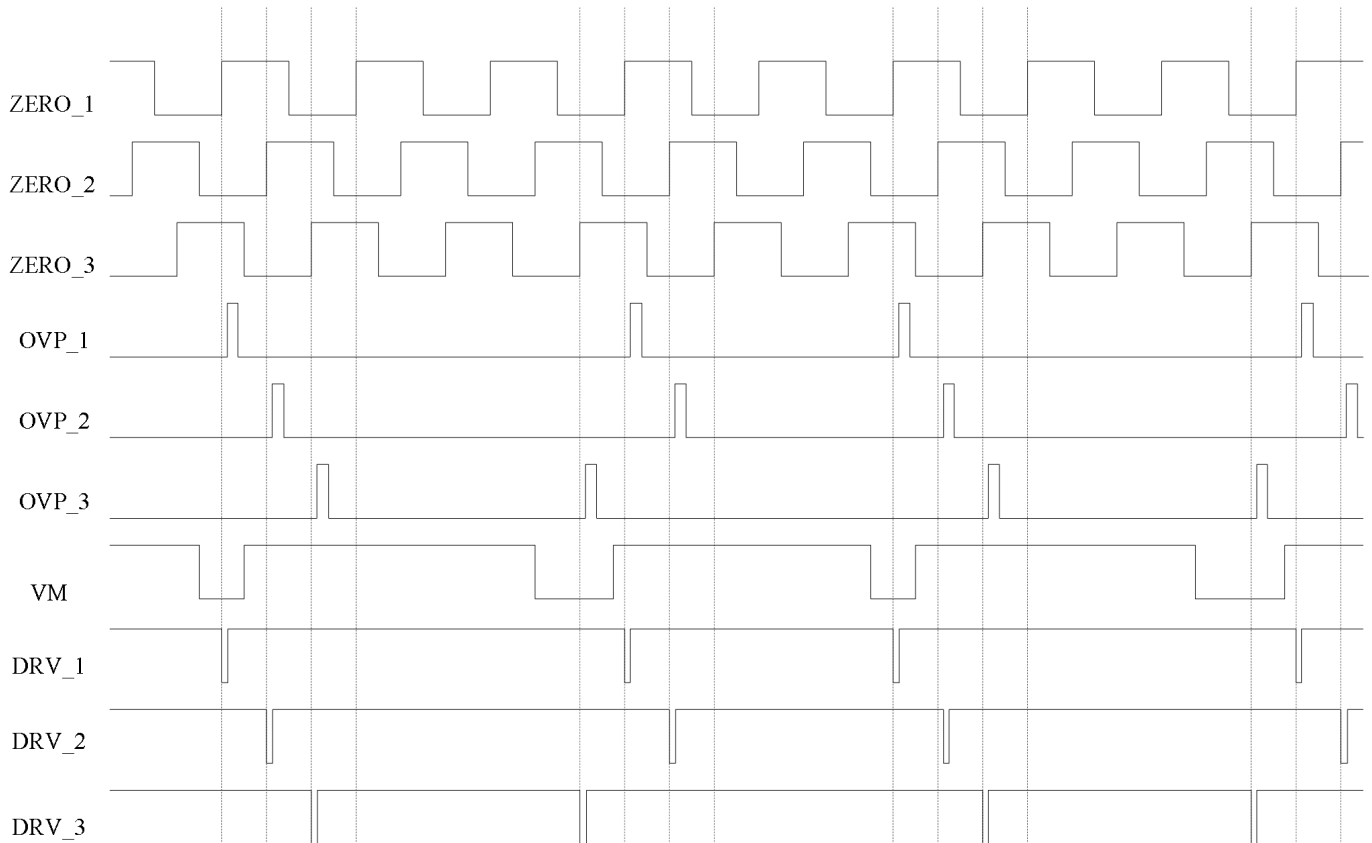

Remarks:

- 1.ZERO_1、ZERO_2、ZERO_3 are the zero-crossing detection signals of each phase voltage.
- 2.OVP_1、OVP_2、OVP_3 are the overvoltage detection signals of each phase.
- 3.VM is for adjusting voltage detection signal, VM_3 is the VM signal that is logically processed.
- 4.DRV_1、DRV_2、DRV_3 are drive output signals of each phase respectively.

Hot plug protection

When the magneto is working, the voltage regulator may be suddenly connected or disconnected for some reason. At this time, the power supply system of the entire chip has not been established, and the high output voltage of the magneto may damage the voltage regulator. For this abnormal usage, increase independent hot plug in the chip protection function, at the instant of the voltage regulator and magneto connection, if the phase voltage is higher than 30V, has strong guidance immediately under the corresponding phase tube MOS tube, close the corresponding phase on tube MOS tube, so as to avoid the damage to the voltage regulator, hot-swappable guarantee system safe and reliable.

Stopped state

When the magneto stops working, the internal control logic circuit of MST007 will enter the sleep state.



Ordering And Marking Information

Product name	Holder Type	Marking information	Minimal package
MST007	LQFP32L	MST007 XXXX	2500PCS

Package Outline

LQFP32L

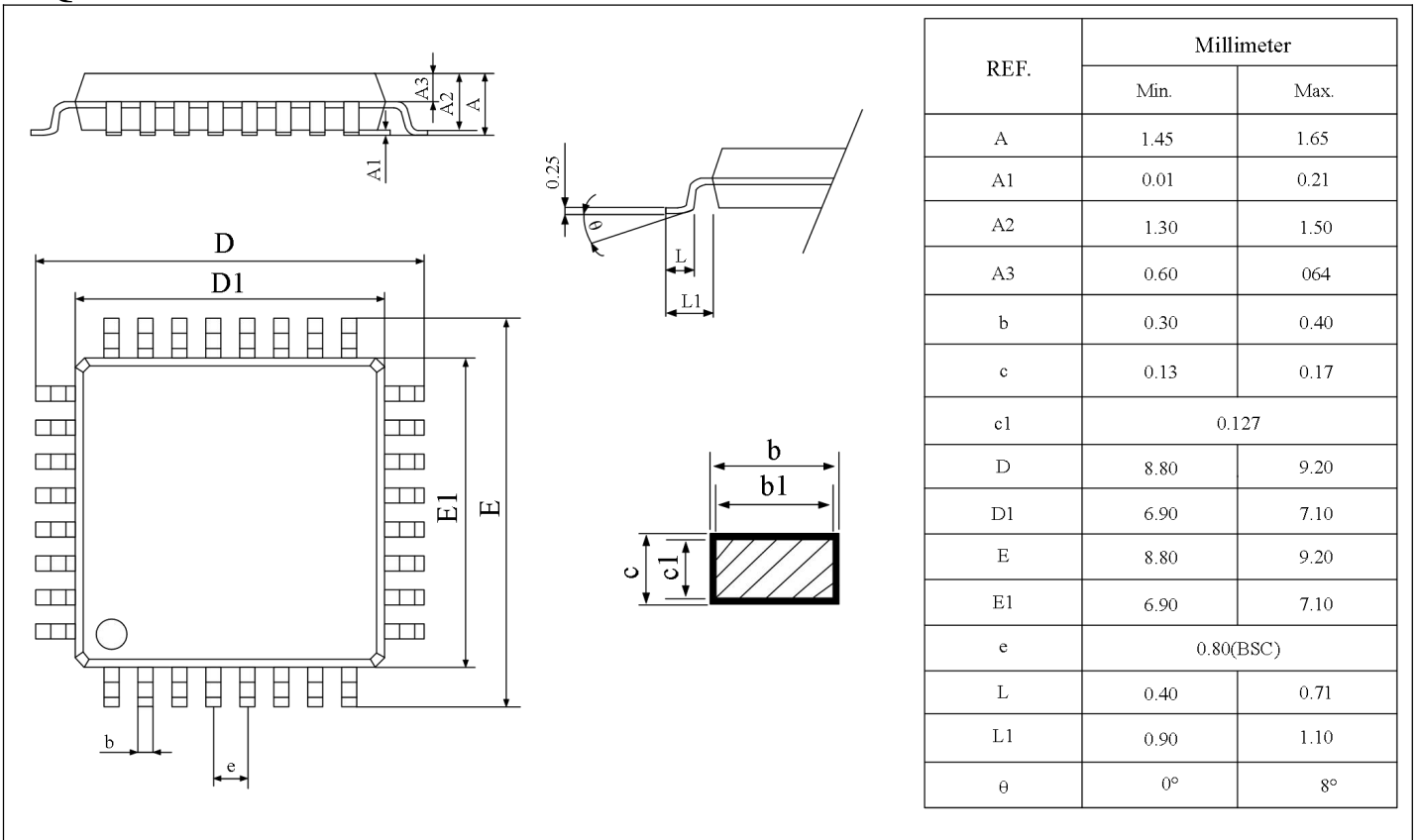

Packing Information

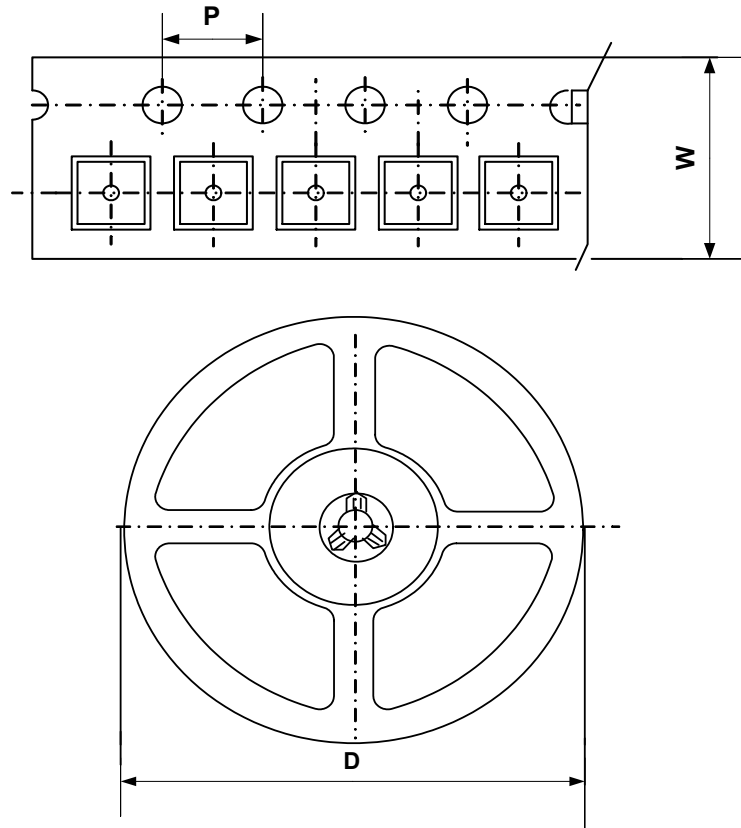

Type	W(mm)	P(mm)	D(mm)	Qty (pcs)
LQFP32L	16.0mm	4.0mm	330.0mm	2500pcs

IMPORTANT NOTICE

MST INCORPORATED MAKES NO WARRANTY OF ANY KIND, EXPRESS OR IMPLIED, WITH REGARDS TO THIS DOCUMENT, INCLUDING, BUT NOT LIMITED TO, THE IMPLIED WARRANTIES OF MERCHANTABILITY AND FITNESS FOR A PARTICULAR PURPOSE (AND THEIR EQUIVALENTS UNDER THE LAWS OF ANY JURISDICTION).

MST Incorporated reserves the right to make modifications, enhancements, improvements, corrections or other changes without further notice to this document and any product described herein. MST Incorporated does not assume any liability arising out of the application or use of this document or any product described herein; neither does MST Incorporated convey any license under its patent or trademark rights, nor the rights of others. Any Customer or user of this document or products described herein in such applications shall assume all risks of such use and will agree to hold MST Incorporated and all the companies whose products are represented on MST Incorporated website, harmless against all damages.

MST Incorporated does not warrant or accept any liability whatsoever in respect of any products purchased through unauthorized sales channel. Should Customers purchase or use MST Incorporated products for any unintended or unauthorized application, Customers shall indemnify and hold MST Incorporated and its representatives harmless against all claims, damages, expenses, and attorney fees arising out of, directly or indirectly, any claim of personal injury or death associated with such unintended or unauthorized application.

Products described herein may be covered by one or more United States, international or foreign patents pending. Product names and markings noted herein may also be covered by one or more United States, international or foreign trademarks.